



Clean combustion. Powerful results.

DELTA-NOx PROVES SUCCESSFUL

SITUATION

In order to meet future emissions regulations and increase the capacity of their Nebraska "O" type boiler, ENSCO required a new, efficient replacement burner. The existing competitor's burner had limited fan capacity and CO emissions over 400 ppm. Lowering CO would not only increase their boiler efficiency, but also help them to comply with future regulations. ENSCO also needed a burner that would meet future NOx levels without the use of expensive flue gas recirculation (FGR). Coen used their new Delta-NOx burner to meet these requirements.

This installation was a tough test for the Delta-NOx burner. The existing windbox was very shallow, the furnace's volume was limited, the air flow was unbalanced, and the fan motor was undersized.

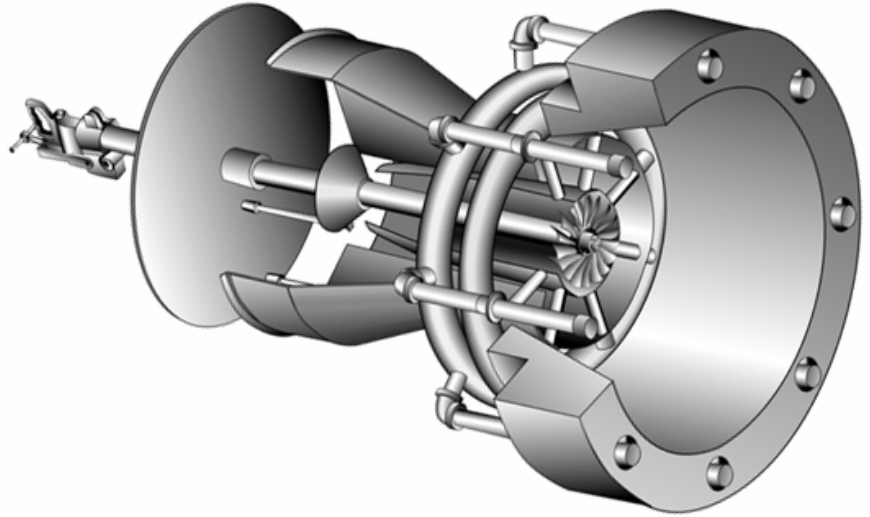

Name:	ENSCO
Location:	El Dorado, Arkansas
Boiler:	Nebraska "O" Type Boiler
Capacity:	60,000 PPH
Heat Release:	110,000 Btu/Ft ³ /Hr
Burner:	New Coen "Delta-NOx"
Fuels:	Natural Gas
Emissions:	0.066 lbs/mmBtu (55 ppm) NOx 0.033 lbs/mmBtu (45 ppm) CO

SOLUTION

The existing fan, windbox and damper were reused to help reduce the retrofit cost. Coen supplied the burner, throat assembly, control valve, turnkey installation and start up services. The lower draft loss of the Delta-NOx solved the problem of fan sizing and allowed the customer to increase steam flow by 20%, eliminating the need for operating the second boiler.

With no moving parts, operation and maintenance of the Delta-NOx is simple. This burner requires no further adjustments after the initial startup. The single point positioning controls for the air damper and Coen "AC" fuel valve provide a reliable and simple interface with the existing equipment. This control package has been proven in many installations worldwide.

Another benefit of the new Delta-NOx burner is that it does **not require flue gas recirculation**. One can avoid the added expense of a separate FGR fan or a larger primary air fan to induce FGR. Additionally, the FGR operating horsepower cost, loss of thermal efficiency, and the installation and maintenance of an FGR system is totally eliminated.

RESULTS

The start up results were even better than expected:

- LOW NOx** - NOx averaged 0.066 lbs/mmBtu over a ten to one turndown (60% NOx reduction).
- LOW CO** - CO averaged 0.033 lbs/mmBtu over load range (85% CO reduction resulted in a 0.1% efficiency gain for the boiler).
- STEAM CAPACITY** - The low draft loss of the Delta-NOx resulted in a 20% increase in steam capacity with the existing air fan.
- LOW OPERATING COST** - Fan operating HP is 10% less even with a 20% increase in capacity. Also, the high operating costs associated with FGR is eliminated.
- STARTUP** - The new Delta-NOx was tuned and set for automatic operation in one day.

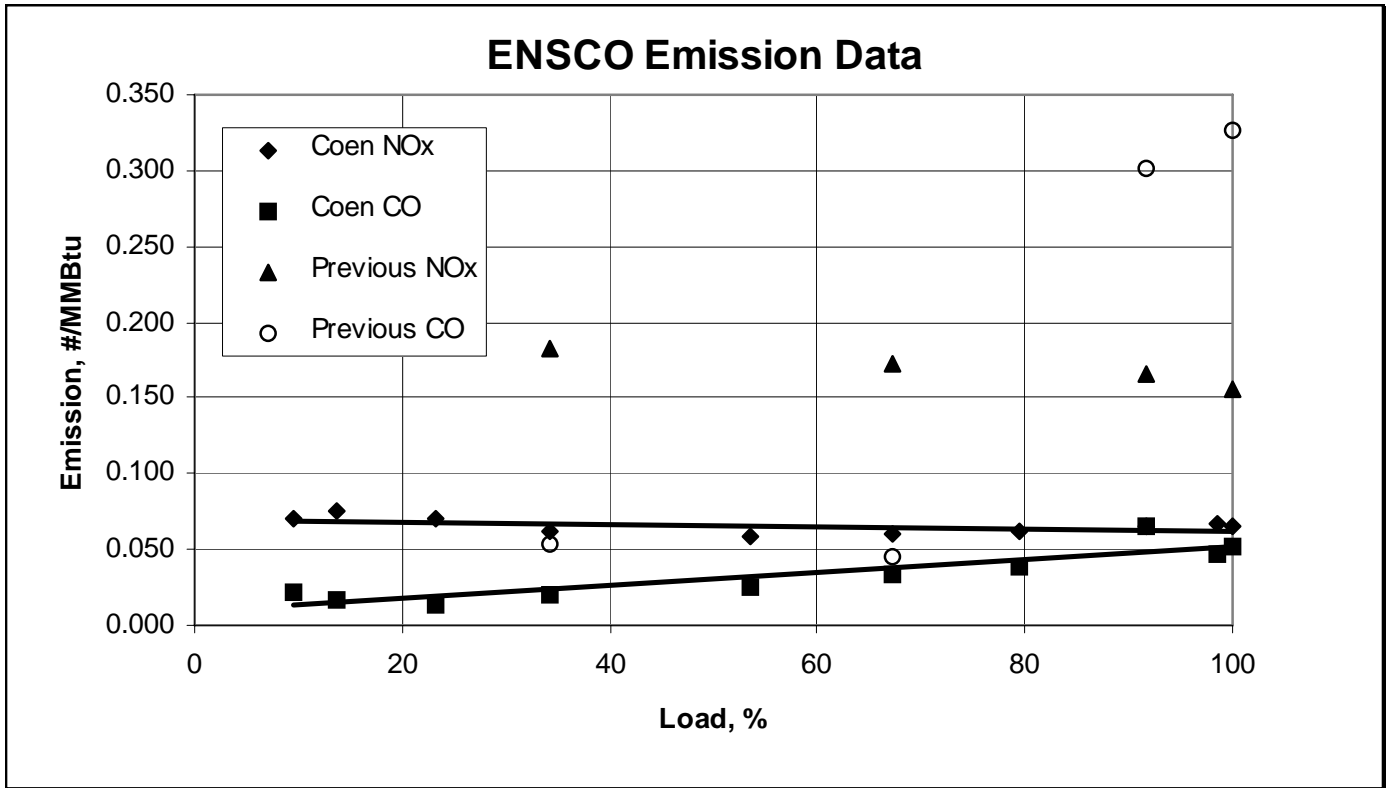

CUSTOMER NEEDS

- ✓ Meets Emission Limits
- ✓ Easy Retrofit
- ✓ Quick Startup
- ✓ Increased Capacity
- ✓ Local Coen Representative

OPERATIONS

- ✓ No FGR Required
- ✓ Excellent Turndown
- ✓ Fan BHP Lowered 10%
- ✓ Lower Operating Cost
- ✓ Steam Flow Increased 20%

AIR QUALITY

- ✓ 0.066 lbs/mmBtu NOx
- ✓ 60% Lower NOx
- ✓ Further NOx reduction possible
- ✓ 0.033lbs/mmBtu CO
- ✓ 85% Lower CO

Strict Federal air pollution regulations create great economic challenges that make it more difficult to remain competitive in a fierce global environment. It is no longer an option, but a necessity for industry to pursue and implement the latest technology providing both economic and environmental benefits.

Since Coen Company has been producing combustion equipment for over 90 years we understand this trend. Coen is committed to providing the latest in combustion and emission control technology to meet the needs of today's tight boiler designs and tomorrow's emissions.

